

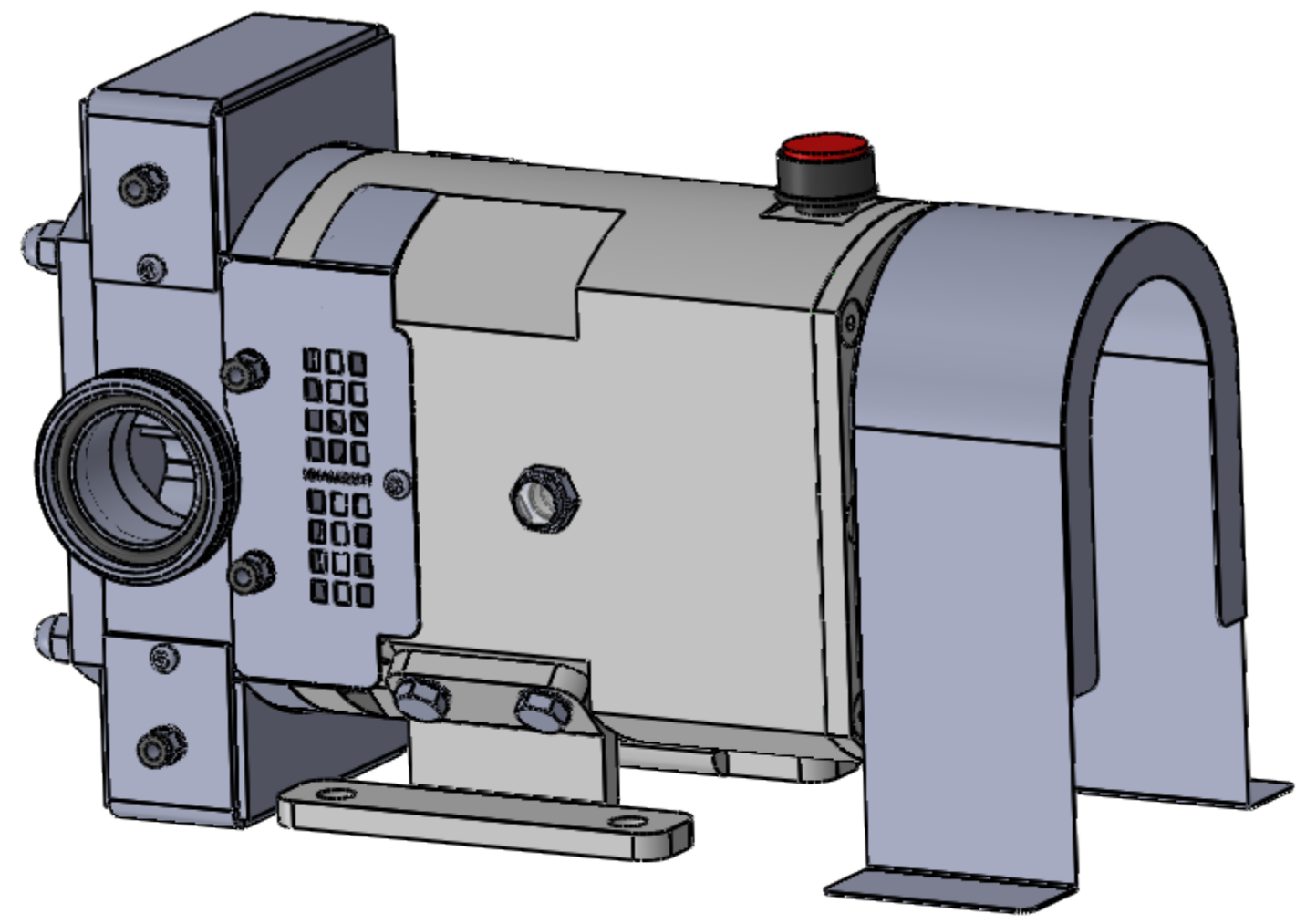

NO.	PART NUMBER	PART NAME	DESCRIPTION	MATERIAL	QTY.	NO.	PART NUMBER	PART NAME	DESCRIPTION	MATERIAL	QTY.
1	FDP+B-65.00.01	HOUSING	129x204x90,25	AISI-316L	1	29	FDP+B-65.00.29	LOBE SCREW O-RING	Ø33,5xØ1,75	VITON	2
2	FDP+B-265.00.02	WING LOBE	Ø101x70	AISI-316L	2	30	FDP+B-65.00.30	LOBE SCREW	Ø34,8x42,7	AISI-316L	2
2	FDP+B-365.02	TRI LOBE	Ø101x70	AISI-316L	2	31	FDP+B-65.00.31	KEY	8x7x40	C45	1
3	FDP+B-65.00.03	FRONT COVER	129x204x14	AISI-316L	1	32	FDP+B-65.00.32	FRONT COVER ORING	Ø	VITON	1
4	FDP+B-65.00.04	DRIVE SHAFT	Ø42x347,5	AISI-329	1	33	FDP+B-65.00.33	OIL PLUG	M16	11SMNPB30	1
5	FDP+B-65.00.05	DRIVEN SHAFT	Ø42x299,5	AISI-329	1	34	FDP+B-65.00.34	OIL GAUGE	M16	AL	1
7	FDP+B-65.00.07	GEAR BOX	129x204x222	GG-20	1	35	FDP+B-65.00.35	HEXAGON HEAD BOLT	M10x25	8.8	4
8	FDP+B-65.00.08	REAR COVER	129x204x10	ST 37	1	36	FDP+B-65.00.36	WASHER	M10	8.8	8
9	FDP+B-65.00.09	GEAR BOX LEGG	98x160x10	ST 37	2	37	FDP+B-65.00.37	HAND PROTECTION SHEET AIRO-L	1x77x200	AISI-304	1
10	FDP+B-65.00.10	BEARINGS	Ø72x35x19	TS11176	4	38	FDP+B-65.00.38	SCREWDRIVER MOUTH BOLT	M5x8	8.8	2
11	FDP+B-65.00.11	SAFETY WASHER	M35	TS3573	2	40	FDP+B-65.00.40	HAND PROTECTION SHEET AIRON-R	1x77x200	AISI-304	1
12	FDP+B-65.00.12	SAFETY NUT	M35	TS3573	2	41	FDP+B-65.00.41	FITTING	1/8		4
13	FDP+B-65.00.13	GEAR L	Ø80x24	15Cr3	1	42	FDP+B-65.00.42	MECHANICAL SEAL RADIAL LIP SEAL	Ø47xØ30x7	NBR	2
14	FDP+B-65.00.14	GEAR R	Ø80x24	15Cr3	1	43	FDP+B-65.00.43	FERULLE		AISI-316L	2
15	FDP+B-65.00.15	DRAGGING BUSHING	Ø63x31	Ck45	2	44	FDP+B-65.00.44	INBUS	M6x25	AISI-304	6
16	FDP+B-65.00.16	INBUS	M6x15	8.8	12	45	FDP+B-65.00.45	SETSKUR	M10x45	AISI-304	4
17	FDP+B-65.00.17	GEAR BOX COVER SEAL	129x204x0,5	KLINGRIT	1	46	FDP+B-65.00.46	NUT	M10	AISI-304	4
18	FDP+B-65.00.18	HEXAGON SOCKET COUNTERSUNK HEAD CAP SCREWS	M8x20	8.8	6	47	FDP+B-65.00.47	BODY HEATING JACKET			2
19	FDP+B-65.00.19	REAR COVER RADIAL LIP SEAL	Ø47xØ28x7	NBR	1	48	FDP+B-65.00.48	GEAR COUPLIN			1
20	FDP+B-65.00.20	BEARING RADIAL LIP SEAL	Ø72xØ42x7	NBR	2	49	FDP+B-65.00.49	WASHER	M10	AISI-304	4
22	FDP+B-65.00.22	MECHANICAL SEAL			2						
26	FDP+B-65.00.26	PIN	Ø8x30	F50k	2						
27	FDP+B-65.00.27	SETSKUR	M10x42	AISI-304	4						
28	FDP+B-65.00.28	HEXAGON DOMET CAP NUT	M10	AISI-304	4						



GENERAL TOLERANCE	ISO 2768	DRAWN BY	DATE	19.10.2020		
WELD TOLERANCE		CONTROL	MATERIAL	-		
PAINTING		APROVAL	PIECE	-	DEGREE	A
COATING		GROUP NAME	LOBE PUMP		GROUP/POS NO	A
HEAT TREATMENT		PART NAME	LOBE PUMP ASSEMBLY		PART NO	FDP+B-65.00
HARNES						